

**NOTES:**

1. LOW POINT PITS SHALL BE LOCATED AT THE T.P.s WHERE DESIGN LEVELS PERMIT.
2. GRADE FROM ROAD INTERSECTION TO LIP AT THE CENTRE OF THE KERB RETURN SHALL BE WITHIN THE RANGE 0.5% TO 6.0%.

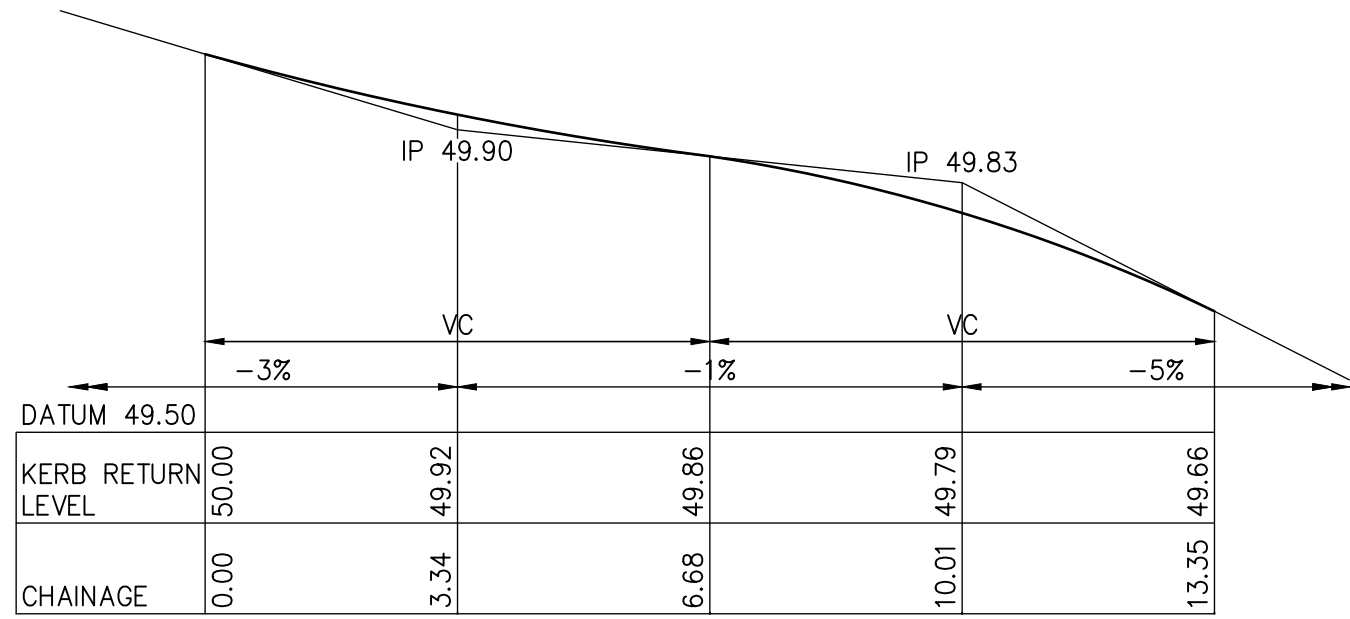

HORIZONTAL 1:100  
VERTICAL 1:10

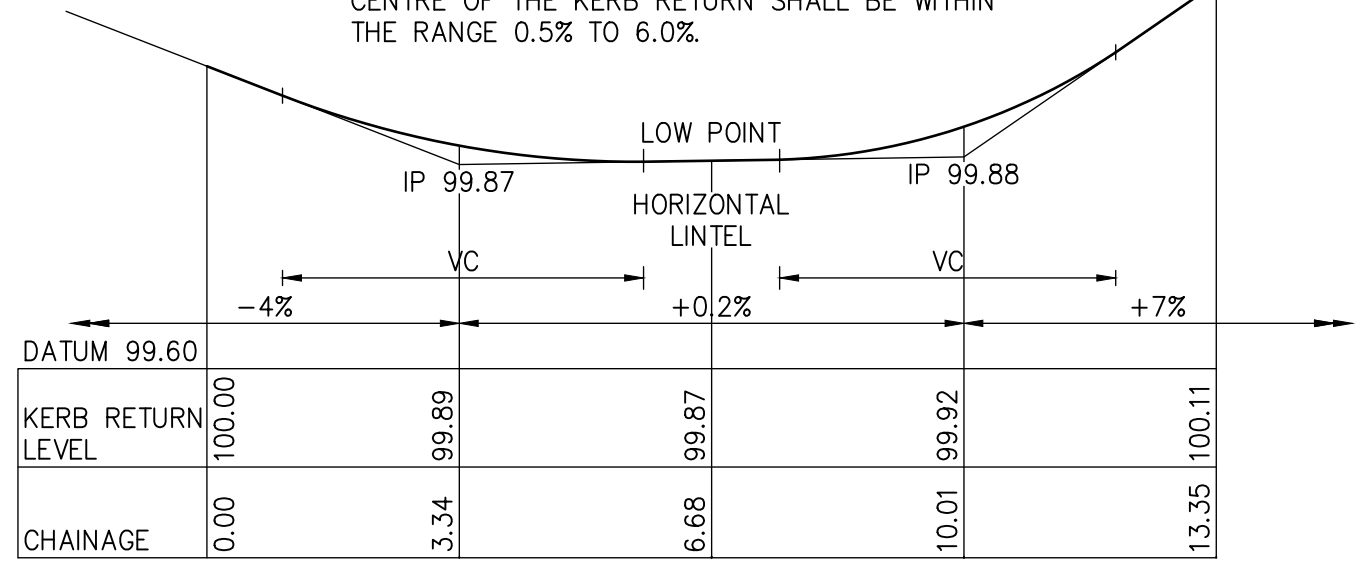

HORIZONTAL 1:100  
VERTICAL 1:10

A	REVISED DRAWING	TZ	25/01/21
ISSUE	AMENDMENTS	DRAWN	DATE



DRAWN .....TZ...  
H 1:100  
SCALE .....V.1:10...  
SHEET SIZE: **A3**

APPROVED  
*[Signature]*  
GROUP MANAGER  
INFRASTRUCTURE SERVICES  
D.L.

<b>WINGECARRIBEE SHIRE COUNCIL</b>			
<b>STANDARD DRAWING</b>			
<b>TYPICAL KERB RETURN DESIGNS</b>			
DATE: 25/01/2021	PLAN No: SD105	SHEET 1 OF 1	ISSUE <b>A</b>